

# DUMA



浙江杜马缝纫机股份有限公司  
ZHEJIANG DUMASEWINGMACHINE CO.,LTD.

地址：浙江省台州市椒江区机场南路58号  
电话：0576-89086969 传真：0576-89086999  
网址：www.cnduma.com



## 500



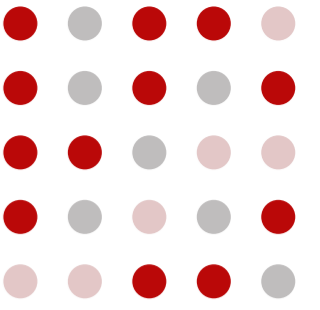

### 步进全自动平台式绷缝机

Stepping Motor driven Flat Bed Interlock with Automatic trimmer & foot lifter



**此款绷缝机多用于针织服装的滚领、滚边、拼接缝、饰边、各种内衣裤、运动衫接缝等。**

**This interlock sewing machine is mostly used for rolling collar, piping, stitching, trimming, various underwear, sweatshirt seams, etc. of knitted garments.**

			 (mm)	 (mm)	 (mm)		 (rpm)
DM500-01W/356	3	4	4.5	5.6	6.5	0.6-1.3	5000
DM500-01K/356	3	5	4.5	5.6	6.5	0.6-1.3	5000

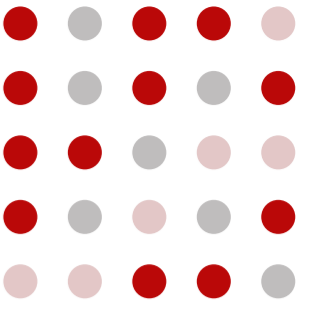

## 500 步进全自动平台式绷缝机

Step-by-step automatic interlock sewing machine



- **一体外观设计** 占用空间少，安装方便；
- 针杆传动机构,采用密封式的设计,安全整洁；
- 整机优越的机构设计和精密的零部件制造适应**高速运转**；
- 步进电机**自动抬压脚**，抬压脚高度可调，声音轻柔，压脚可以轻轻放下，防止压坏面料；
- 步进电机**自动剪线**，线头长短稳定，切线机构简单可靠，故障率低，切线声音轻。

- Less space and is easy to install;
- Sealed design of the needle bar transmission mechanism , safe and tidy;
- Superior mechanism design and the precise parts manufacturing are suitable for high-speed operation;
- Adjustable height of the presser foot , the presser foot can be gently lowered to prevent the fabric from being crushed;
- Stable thread length , the mechanism is simple and reliable, the failure rate is low, and the sound is soft.

## 1 步进电机双驱动

内置式步进电机剪线，步进电机抬压脚功能；剪线、抬压脚响应快，声音轻柔。

The built-in stepper motor thread trimming and lifting foot responds fast and sound soft.

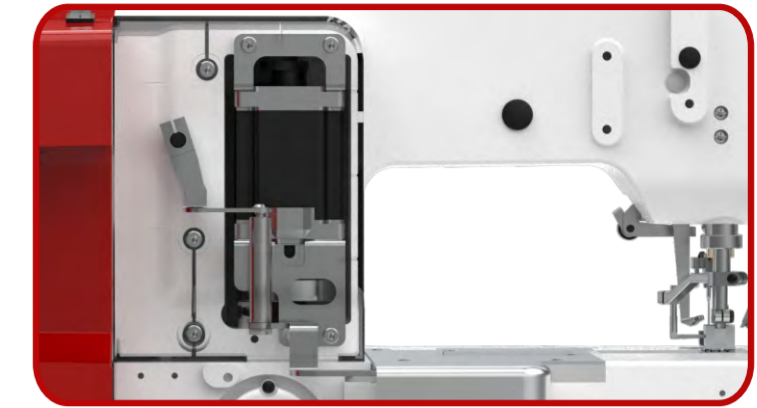

## 2 同步带传动

同步带传动使整机在高速下运行稳定精准。

The synchronous belt drive makes the whole machine run stably and accurately at high speed.

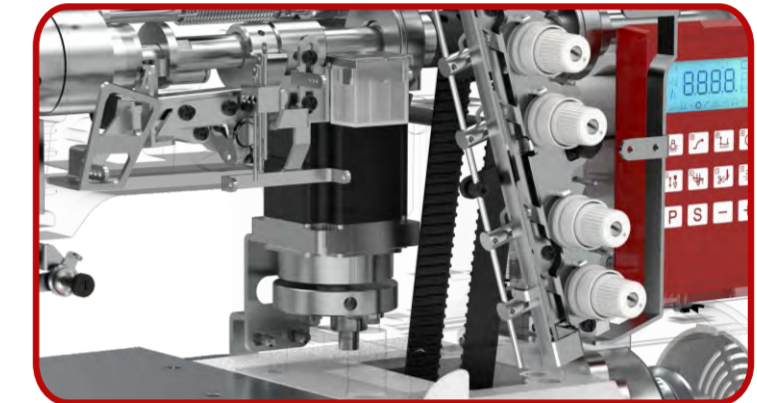

## 3 打线凸轮

外置打线凸轮，调整收线灵活、便捷。

The external threading cam makes it flexible and convenient to adjust and take up the thread.

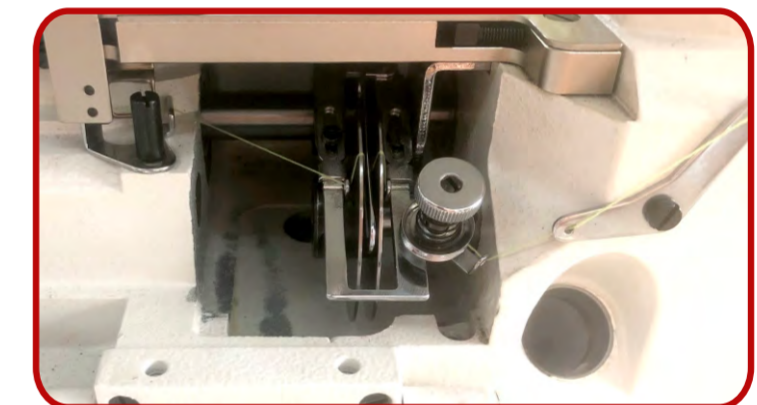

## 4 伺服电机驱动

启动快、停针准、噪音低、振动小；  
最高转速可达5000转/分。

Servo motor driving: with the function of quick start, accurate needle stop, low noisy and low vibration. Max. speed: 5000rpm



## 5 多功能按键屏

多功能按键显示屏，操作简单易懂，功能齐全。

Multi-function button display, easy to understand and complete functions.

